

Eagle Quantum™ Premier 8 Channel Relay Module EQ3720RM

DESCRIPTION

The 8 Channel Relay Module is specially designed to expand the Output capability of the Det-Tronics Eagle Quantum Premier™ System.

The unit is designed to provide eight relay output channels for use with non-supervised devices (PLCs, fans, dampers, etc.) or devices with their own supervision.

The relay module can be mounted directly to a panel, or it can be DIN rail mounted utilizing the DIN rail adapter. System status can be determined using the troubleshooting procedures, Eagle Quantum Safety System Software (S³) and the status indicators on the module.



THEORY OF OPERATION

The Relay Module provides unsupervised, isolated relay output capabilities to the system. The eight form “C” dry contacts are rated at 30 VDC/MAC.

LED INDICATORS

LEDs on the front panel of the relay module are provided for indicating device status conditions. The LED's are tested upon power up to verify their operation.

MOUNTING

The relay module is DIN rail or direct panel mountable for configurations requiring installation in NEMA or IP enclosures. DIN rail and mounting clip options must be specified at the time of order. Refer to the “Specifications” section for mounting arrangements and dimensions.

FEATURES

- Expands the output capabilities of the Det-Tronics Eagle Quantum Premier™ system
- Monitors eight independent relay output channels
- Individual channel LEDs indicate Active and Fault status
- Provides remote output capabilities via LON/SLC
- Panel or DIN rail mounting
- Power LED display
- Plug-in wiring connectors
- RFI and EMI hardened (CE Marked).

SPECIFICATIONS

POWER REQUIREMENTS—

3 watts nominal, 4 watts maximum.

INPUT VOLTAGE—

24 vdc nominal, 18 to 30 vdc. 10% overvoltage will not cause damage to the equipment.

RELAY CONTACT RATING—

2 amperes (resistive) at 30 Vdc maximum.

OUTPUT STYLE—

Type "C" relay (normally open/normally closed).

RESPONSE TIME—

Output actuates in <0.1 second after acknowledging an alarm command message.

LON COMMUNICATION—

Digital communication, transformer isolated (78.5 kbps).

TEMPERATURE RANGE—

Operating: -40°F to +185°F (-40°C to +85°C).
Storage: -67°F to +185°F (-55°C to +85°C).

HUMIDITY RANGE—

5 to 95% RH, non-condensing.

DIMENSIONS—

Refer to Figure 1.

SHIPPING WEIGHT—

1 pound (0.45 kilograms).

CERTIFICATION—

FM / CSA: Class I, Div. 2, Groups A, B, C, D (T4).
Class I, Zone 2, Group IIC (T4).

CENELEC/CE: ATEX/EMC Directive Compliant.

CE 0539 II 3 G

EEx nC IIC T4

DEMKO 03 ATEX 135246U

T4 (Tamb = -40°C to +85°C).

V_{in} = 24 vdc ±10%.

Special conditions for safe use:

The device shall be installed in an enclosure that complies with all relevant requirements of EN 50021: 1999, and provides a degree of ingress protection of at least IP54. The device may only be installed, connected or removed when the area is known to be non-hazardous.

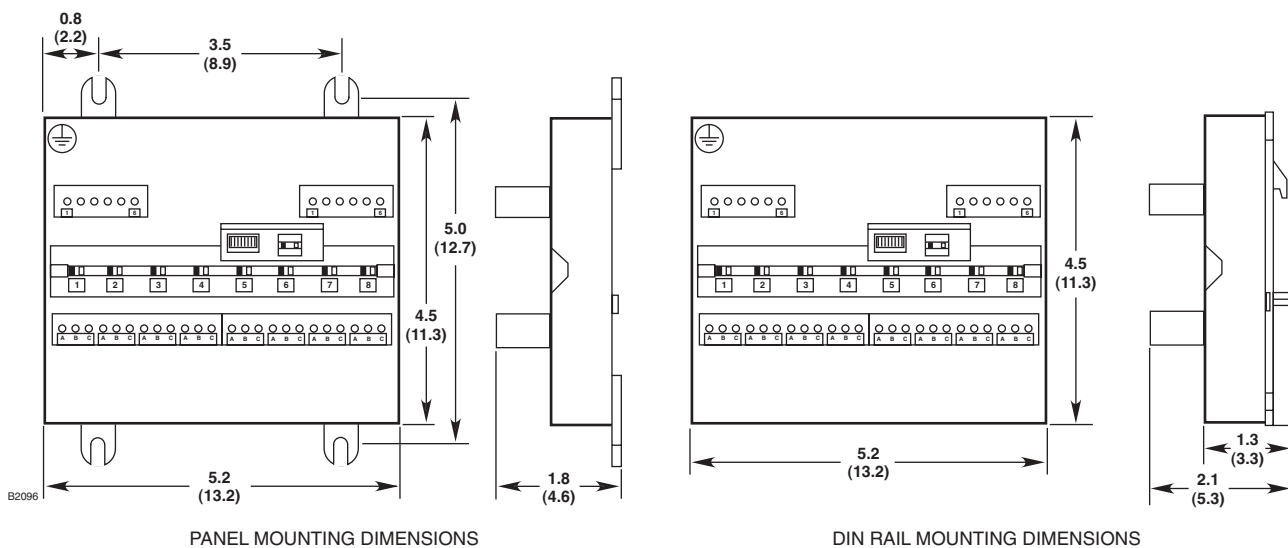

Figure 1—Dimensions of the Relay Module in Inches (Centimeters)

INSTALLATION

MOUNTING

The Relay Module must be properly installed in a suitable enclosure that is rated for the location. The enclosure must provide space to install and wire the relay module and must also provide for ground wire termination. Access into the enclosure must be gained by using a special tool to open the enclosure. The enclosure should be rated for the temperature range of the location plus the temperature rise of all equipment installed inside the enclosure. The enclosure must be rated for electrical equipment that is going to be installed.

NOTE

It is recommended to maintain a minimum of 4 inches clearance between the module and other equipment to provide adequate room for wiring and ventilation.

WIRING

All electrical connections are made to the field wiring connectors furnished with the module. (Connectors accept up to 12 AWG wire.) Refer to Figure 2 for identification of module wiring terminals.

Connector P1, Terminals 1 to 6 24 Vdc Power Input

- 1 — +24 VDC
- 2 — GND
- 3 — Shield*
- 4 — +24 VDC
- 5 — GND
- 6 — Shield*

*Shields on power wires are optional unless required by local codes.

Connect the module power supply to terminals 1 and 2. If additional terminals are required for powering other devices, these devices should be connected to terminals 4 and 5. Shields are to be connected to terminals 3 and 6 — chassis (earth) ground terminals.

Connector P2, Terminals 1 to 6 LON Terminals

Be sure to observe polarity when wiring the LON.

- 1 — "A" side of signaling circuit for COM 1
- 2 — "B" side of signaling circuit for COM 1
- 4 — "A" side of signaling circuit for COM 2
- 5 — "B" side of signaling circuit for COM 2
- 3 & 6 — shield connections (shields required).

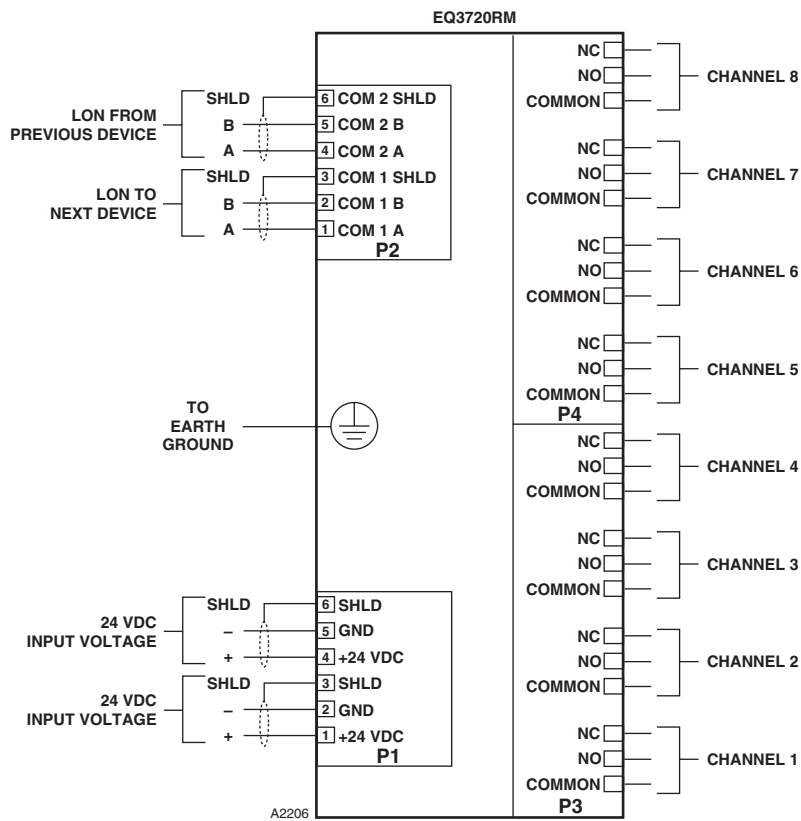

Figure 2—Relay Module Wiring Terminal Configuration

Connectors P3 and P4

Unsupervised Output Ancillary Applications (Unrelated to Fire Detection/Protection)

Connect external wiring to the appropriate terminals on the relay module terminal block. See Figure 2.

CONFIGURATION

Setting Relay Module Network Address

One unique network address must be assigned to each relay module. The address is set by the 8 switch DIP assembly on the relay module.

When using the switches located on the relay module, the address is binary coded and is the sum of all switches placed in the "closed" position.

Each discrete point of a relay module has a tag number and a descriptor for unique identification.

Det-Tronics S³ Safety System Software is used for device configuration.

ORDERING INFORMATION

When ordering, please specify:

EQ3720RM 8 Channel Relay Module

Options Panel Mount
 DIN Rail Mount

For additional information or for assistance in designing a system to meet the needs of a specific application, please contact:

Detector Electronics Corporation
6901 West 110th Street
Minneapolis, Minnesota 55438 USA
Operator: (952) 941-5665 or (800) 765-FIRE
Customer Service: (952) 946-6491
Fax: (952) 829-8750
Web site: www.detrronics.com
E-mail: detrronics@detrronics.com



Detector Electronics Corporation

6901 West 110th Street • Minneapolis, Minnesota 55438 • Operator (952) 941-5665 or (800) 765-FIRE
Customer Service (952) 946-6491 • Fax (952) 829-8750 • www.detrronics.com • E-mail: detrronics@detrronics.com